

Soltron

801233 / Index „b“ / us / 01.2004

Operating Instructions

S-40 Champ * Super**

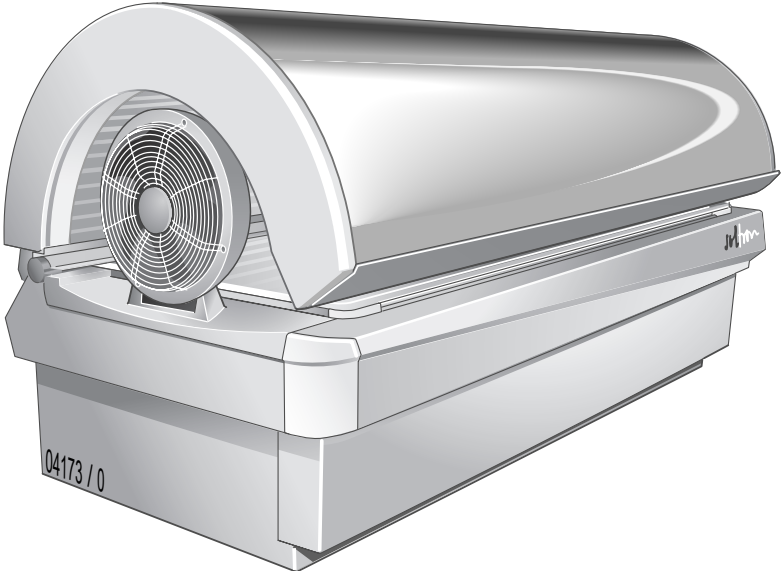

Identify your tanning device

For contact with customer service, please write down the device number of your tanning device.

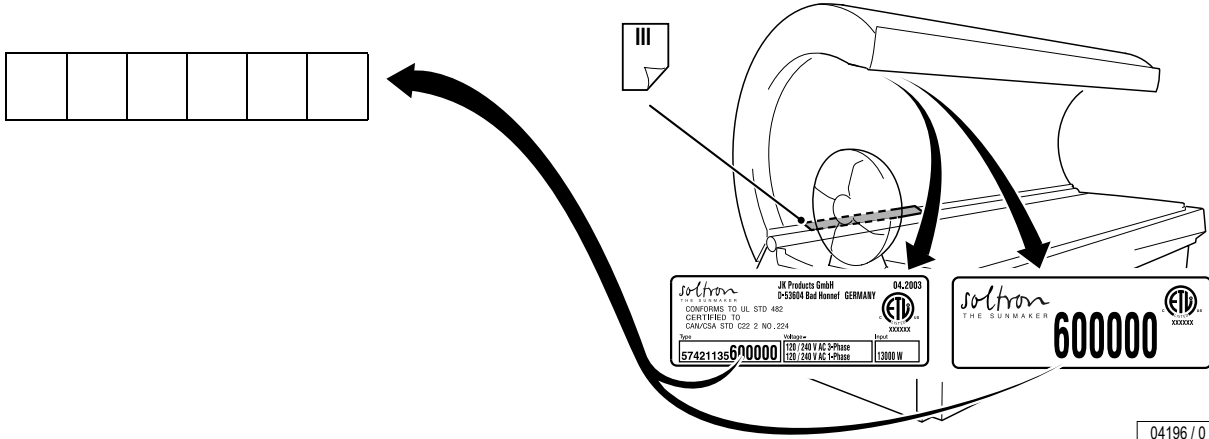

Global Service Division
#1 Walter Kratz Drive
Jonesboro, Arkansas 72401

 (800) 445 0624

04196 / 0

DANGER ULTRAVIOLET RADIATION

Follow instructions. Avoid over-exposure as with natural sunlight. Over-exposure can cause eye and skin injury and allergic reactions. Repeated exposure may cause premature aging of the skin and skin cancer.

Maximum Tanning Time is 15 Minutes

Recommended Exposure Schedule

Skin Type	Week 1 1st - 3rd Treatments	Week 2 4th - 6th Treatments	Week 3 7th - 10th Treatments	Week 4 11th - 15th Treatments	Weekly Subsequent Treatments
II - Fair	3 Min.	7 Min.	10 Min.	12 Min.	15 Min.
III - Average	3 Min.	7 Min.	10 Min.	12 Min.	15 Min.
IV - Brown	3 Min.	8 Min.	12 Min.	15 Min.	15 Min.
V - Dark Brown	3 Min.	8 Min.	12 Min.	15 Min.	15 Min.

WEAR PROTECTIVE EYEWEAR! Failure to do so may result in severe burns or long term injury to the eyes.

Certain medications or cosmetics may increase your sensitivity to the ultraviolet radiation. Consult a physician before using sunlamps if you are using medication, have a history of skin problems or believe yourself to be especially sensitive to sunlight. If you do not tan in the sun, you are unlikely to tan from the use of this product.

This unit utilizes UVA lamps. Replace only with **Soltron VHP 15 120W Super Power and JK 100723 400W (face tanner)** or recognized equivalents. To obtain recommended exposure at a minimum distance of 1/2" (13mm) measured with a standard ruler, lie on acrylic surface of lounge and lower canopy. Canopy will stop at the correct distance from lounge acrylic surface.

Warning: The use of any other position may result in overexposure!

Tanning can begin on a regular basis. An appearance of tanning normally appears after a few exposures and maximizes after four (4) weeks of exposure following the recommended exposure schedule for skin type. In order to provide for maintenance of a tan a maximum of two (2) weekly 15 minute sessions is recommended from the fifth week onward.

Use protective eyewear (Part No. Schmeder 2255 Red or recognized equivalents) when equipment is on. Read and follow instruction booklet before using this product. To avoid electrical shock during maintenance disconnect power from unit.

Part No: 801191a



Note:
Description of
skin types see
Page 15.

04438 / 0

"This product is in conformity with performance standards for sunlamp products under CFR21 Part 1040."

Foreword

Dear Customer,

The Soltron device you have purchased is a technically advanced and powerful microcomputer control system. Your device was manufactured with the greatest care and precision. It went through numerous quality and safety checks in order to guarantee trouble-free, safe operation. But you too may make a significant contribution to your long-term satisfaction with your device. Following the tips and instructions in the instruction manual will ensure you enjoyment and pleasure with your device.

In case of any questions, we are always at your disposition¹⁾.

Your sincerely

Soltron Inc.

- Read and observe the information in this instruction manual. This will enable you to prevent accidents and provide you with a reliable device ready for use.
- Always observe the local and federal regulations and legal requirements as well as the valid environmental protection regulations.

1) ☎ 1-866-243-9861

Table Of Contents

Intended use	7	Maintenance	Fold-out page, 27
Danger of damage to persons	7	Maintenance, overview	27
Meaning of symbols	9	Maintenance intervals, installed lamps and order numbers	28
Guidelines	11	Cleaning/replacing UV low-pressure lamps in sunbed base	33
Export	11	Cleaning/replacing UV low-pressure lamps in canopy	35
Equipment	11	Cleaning/replacing UV high-pressure lamps/filter panels in canopy	37
Accessories	11	Cleaning filters in sunbed base	40
Product information	12	Cleaning/replacing filter mats in canopy	41
Maintenance and care	12	Troubleshooting	42
Cleaning	13	Index	43
Environmental protection information	14	Warranty	45
General tanning instructions	14	Timer operation	see separate manual
Skin types	15		
Operation	Fold-out page, 17		
Overview, operating table	18		
Accessories	18		
Settings during start-up	20		
Terminate tanning session	20		
Regulating face tanner	21		
Regulating surround cooling	22		
Technical Data	24		



Note:

Technical changes are reserved with respect to the illustrations and specifications in this instruction manual. Reprinting and reproduction, in whole or in part, of this manual is only permitted with our previous written approval and with specification of the source.

Safety

Description of warning signs

Danger notes, damage to persons:



Type and source of danger, e.g. "DANGER – High voltage!"

DANGER!

Description of the consequences, e.g. "You can be killed or injured by an electric shock!"

Countermeasures:

- Disconnect device from power supply before opening.
- Do not reach into the inside or change lamps with the device switched on.

Warning notes, damage to persons:



Type and source of danger, e.g. "Warning – hot surface!"

WARNING!

Description of the consequences, e.g. "You can burn your hand (skin, face)!"

Countermeasures:

- Do not touch the lamps and nearby surfaces.
- Wait until lamps and surfaces have cooled down.

Caution notes, property damage:



CAUTION!

The word "CAUTION" with this label points out that danger for devices, materials and the environment can be expected here.

Important information:



Note:

This symbol does not identify safety notes, but states information for a better understanding of the processes.

Intended use

Intended use

The tanning device is intended exclusively for cosmetic tanning of the human skin:

- This device is used for tanning one adult person at a time.
- The user wears suitable eye protection that blocks UV radiation during tanning.

Any other use shall be considered improper. The manufacturer cannot be held liable for damage or injuries resulting from improper use. The operator bears the sole risk for this.

The proper use also includes compliance with the manufacturer's instructions, operating, maintenance and regulation conditions. The device may only be operated, maintained and repaired by persons familiar with these tasks and that have been informed of the dangers involved.

Important notes for the studio operator

- As the operator you are responsible for informing users on possible risks during tanning.
- All danger and safety labels attached to the device must be observed! Do not remove them!
- No safety equipment (e.g. panel switch) may be removed or deactivated which can impair the safe operation of the device!
- The device may only be operated in proper condition!

Danger of damage to persons



DANGER!

DANGER – High voltage!

You can be killed or injured by an electric shock!

Assembly and electrical connection must comply with the national and local regulations.

– Assembly, installation, upgrading or repair of the device may only be carried out by specially trained and instructed personnel.



WARNING!

Warning – ultraviolet radiation!

Unprotected tanning may result in eye injuries and eye diseases.

The unprotected eye can become inflamed on the surface, and in certain cases the retina can be damaged by excessive radiation. Cataracts can form after frequently repeated exposure to radiation.

– Inform users to close their eyes during tanning and use the included protective goggles that block UV (Order No. 84592¹⁾).

1) Global Service Division – see page II.

Danger of damage to persons



Warning – ultraviolet radiation!

WARNING! As with natural sunlight, overexposure can cause eye and skin injury and allergic reactions. Repeated exposure may cause premature aging of the skin and skin cancer. Wear protective eye wear; failure to may result in severe burns or long-term injury to eyes.

Occasionally, persons using the tanning device will experience a slight reddening of the skin – usually in small patches – after the second or third session. This redness is often accompanied by an itching sensation. This may be nothing more than a heat “rash” caused by heat from the lamps within the device. It is generally very limited and caused by constant contact of the skin with the acrylic surface. It should go away within approximately 24 hours and should not reappear. This rashing can be lessened or prevented by applying moisturizer lotion to the affected area after the tanning session is completed.

- Follow instructions.
- The time between two tanning sessions must be at least 24 hours!
- Increasing tanning also requires an extension of the exposure time (= radiation time) or after a certain degree of tanning has been achieved, a further intensification is not possible. However, the radiation time may not be extended as desired within the scope of the permissible radiation doses! Therefore, only a certain degree of final tanning dependent on the skin type can be achieved without endangering your health.
- Inform users about proper tanning – see page 14.



Warning – ultraviolet radiation!







WARNING! Danger of long-term consequences.







- Nursing infants and small children through age 7 years may not use this device.
- The following applies to minors under the age of 18 years: Only use tanning devices in agreement with a parent or guardian, or after consulting a physician.
- While there is no immediate clinical evidence of UVA exposure and its effects upon expectant mothers, it is strongly advised that expectant mothers be discouraged from using the tanning unit.

Please read and observe ...

Meaning of symbols

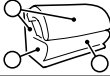
Symbols for Description, Operation and Maintenance

General Symbols	
	Inform Customer Service
	Soltron key
	Do not touch, hot surface!
	UV low-pressure lamp(s)
	Starter for low-pressure lamp(s)
	UV high-pressure lamp(s)
	Filter panels

General Symbols	
	Cleaning and disinfectant agents
	Part/article number (for orders)
Operation	
	Description
	Press button
	e.g. Press button for 2 seconds 2s
	Duration: 3 minutes

Please read and observe ...



Loudspeaker



Headphone connection

Technical data



Maintenance



Caution, safety switch!



Unscrew/release screw with Soltron key



Tighten/lock screw with Soltron key



Two persons are required for this work step



Suction cup



Cleaning



Replacing



Clean or replace depending on soiling



Visual inspection



Filter/filter mat

...

Continuation of work steps on next page



End of work step

Troubleshooting



Please read and observe ...

Guidelines

This device was built according to UL STD 482, certified to CAN/CSA STD C22.2 2 No. 224.



CAUTION – Air inflow and outflow

Do not change, obstruct or block the air inflow and outflow area to the device or make any unauthorized changes to the device. The manufacturer shall bear no liability for damage or injuries resulting from such actions.

Export

We would like to point out that the devices are exclusively intended for use in the US and Canada, and may not be exported to other countries and operated there! The manufacturer shall assume no liability whatsoever in case of non-observance! We explicitly emphasize that high liability risks may occur for the exporter an/or the operator in case of non-observance.

Equipment

The equipment of the devices differs depending on the model.

In this instruction manual all standard and optional components/functions are taken into account which must be observed during operation and/or when performing maintenance.

Accessories

Some accessory parts are taken into account in the maintenance schedule beginning on Page 29, however this does not automatically mean that your device is provided with this equipment (e.g. Air Condition).

An overview of the possible accessories is provided in the sales documentation.

Please read and observe ...

Product information

Acrylic glass panels

The acrylic glass panels for the tanning devices are produced of acrylic glass developed especially for this application. The acrylics used are characterized by a particularly high UV permeability and resistance, as well as an easy-care, hygienic surface that is gentle to the skin.

The acrylic glass panels are formed to their shapes for the specific devices in a technically complex production process. Despite state-of-the-art production know-how, the presence of minor spots, air bubbles or streaks in the acrylic panels is unavoidable. In addition, microfine hairline cracks can occur on the bed surface during operation.

These occurrences are material-dependent and are unavoidable in processing, however have no significant effect on the utility value and can therefore not be recognized as defects.



CAUTION!

Cosmetics or sun screen products must be removed prior to tanning as they can cause damage (e.g. fine cracks on the surface) when used continuously.

Maintenance and care



DANGER!

Extreme danger! High voltage!

During maintenance work there is a danger of touching live parts and receiving a fatal electrical shock.

- Disconnect device from power supply before opening – also see Page 27.
- Do not reach behind covers, do not open the device and do not replace lamps with the device switched on.

Maintenance and care play a major role in deciding whether the device meets the requirements placed on it in a satisfactory manner. The compliance with the specified maintenance intervals and the careful conducting of the maintenance and care work are therefore absolutely necessary – see Page 29 ff.

Remount any protective devices (e.g. filter panels) after completing work.



CAUTION!

Only use original spare parts of the same type or compatible parts! The use of other parts voids the conformity! Any liability is excluded in case of damage or injury proven to be the result of the use of non-original spare parts.

Please read and observe ...

Cleaning

Acrylic glass surfaces



CAUTION!

Do not rub with a dry cloth – danger of scratching!
For fast, hygienic proper cleaning of acrylic glass surfaces, use the specially developed fast disinfectant cleaner Anti-fect®.

Concentrated disinfectants or solvents (e.g. Lysoform, ethyl alcohol or other liquids containing alcohol) may never be used for cleaning. Other unsuitable cleaning agents that cause damage due to chemical reactions may also not be used!

Plastic surfaces

For cleaning the other plastic surfaces, it is best to use warm water and a leather cloth. Never use aggressive cleaning agents containing alcohol, e.g. the commercially available Sagrotan, or essential oils. These may lead, in the long run, to damages not covered by the guarantee.

During cleaning a slight discoloration of the leather cloth by the rubber seals must be expected for production-related reasons.



Note:

Prevent damage to the acrylic glass and plastic surfaces. Remove rings, watches, bracelets etc. before the start of cleaning work.

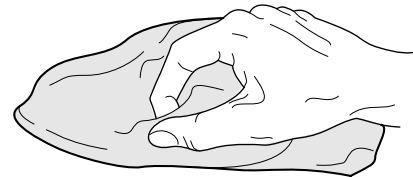
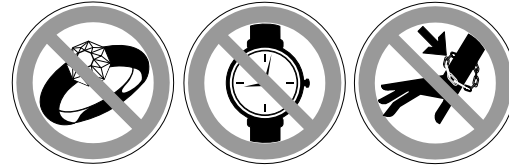

02756 / 0

Please read and observe ...

Environmental protection information

Environmental Declaration – The JK Corporate Group

The JK corporate group is subject to the strict regulations of EC Directive 761/2001 and the standard DIN ISO 14001, and undergoes regular internal and external environment audits performed by trained auditors.

Environmental regulations – disposal of lamps

UV low-pressure lamps and UV high-pressure lamps contain fluorescent materials and other waste containing mercury.

According to the national waste disposal laws and in accordance with the municipal waste regulations, proof must be provided of the proper disposal of UV lamps.

Your local environmental agency will be happy to assist you with the disposal of UV lamps.

General tanning instructions

Who can get a tan?

Anyone who also gets a tan in natural sunlight. Persons with sensitive skin even tan more pleasantly and with fewer worries, as the radiation dosage can be exactly defined with sunbeds.

Certain drugs – particularly those that produce photosensitivity – may cause individuals under the influence of this type drug to experience adverse effects and those people should avoid exposure to UV sources of all kinds. Doctors will advise people taking these drugs to possible adverse effects.

The speed and intensity with which someone tans are dependent on the skin type and the individual melanin quantity in the skin. No two individual skin tones are the same. A tan to one person may be different to another and treatment length may vary.

What is Melanin?

The brownish pigment produced by special cells in the base layer of your skin determines the individual's tan. As the skin is exposed to the ultraviolet light, the melanin is activated and combines with protein cells that rise to the skin's surface, thus producing a tan. The amount of melanin in your body determines how quickly and dark you tan. The more melanin produced and exposure time an individual has, the faster and deeper the individual will tan.

Please read and observe ...



Note:

The tan produced by the tanning unit is a deep, rich “Cosmetic” tan. However, regardless of how dark an individual may tan on his system, it will not provide adequate protection against overexposure to natural sunlight or UVB tanning systems.

Which tanning times are recommended?

Although there is virtually no reason to worry about sunburn with the UV tanning method, some consideration should initially be given to individual skin sensitivity.



Danger of skin injuries and skin diseases!

DANGER! Although UVA radiation is relatively harmless compared to natural sunlight, excessive tanning times can lead to the skin becoming red and to burns.

- Comply with the recommended tanning times, see Page II.

Once you have a tan, 1 to 2 tanning sessions per week are usually sufficient to maintain it.

Should you use sun screen?

No! It is recommended to not use sun screens, oils or lotions intended for outdoor use. Cosmetic sun screens with a sun protection factor (SPF) are intended to filter out the sun's aggressive rays. However, the light of

our sunbeds only contains extremely small quantities of comparable rays, making this kind of protection unnecessary. On the contrary, the skin should be thoroughly cleaned and dried before each sunbath. Many facial makeups have oil bases and should be removed prior to a session.

Adequate ventilation of the room or booth housing the tanning device is required for proper and comfortable operation. Your tanning device will perform best at the ambient temperature of 75 °F to 90 °F.

It is recommended that, following a tanning session, a skin moisturizer be applied. This promotes a smoother, more even looking tan.

Skin types

For the recommended exposure schedule (see page III):

Skin type II:

This is the individual that usually burns easily and severely, tans minimally or lightly and peels.

Skin type III:

Often referred to as “Average” complexion, burns moderately and tans about average.

Skin type IV:

This individual burns minimally, tans easily and above average with each exposure.

Skin type V:

This individual's system rarely burns, tans easily and substantially.

Please read and observe ...

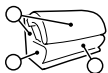

Tanning

Start and end of tanning

The device is started automatically with an internal or external timer and automatically stopped after the preselected time. The fan continues to run for approx. three (3) minutes (fan delay) to sufficiently cool the device.



Note:

Timer instructions: see separate manual.

Preparation time

Before the UV lamps automatically go on, you have a few minutes to prepare yourself. During the preparation time you can switch on the UV lamps at any time by pressing the START/STOP button.

- Remove your clothes and all jewelry.
- Remove make-up and other cosmetics.
- Remove glasses. Contact lenses can be worn under the protective goggles.
- Put on the protective goggles.
- Lie down on the bed surface.
- Close the canopy.

Depending on the controller, the tanning device starts up after a short time automatically. The tanning device is operating when the UV lamps are on and the fans are running.

If the device fails to start up when you have closed the canopy:

- Press START/STOP to start tanning.

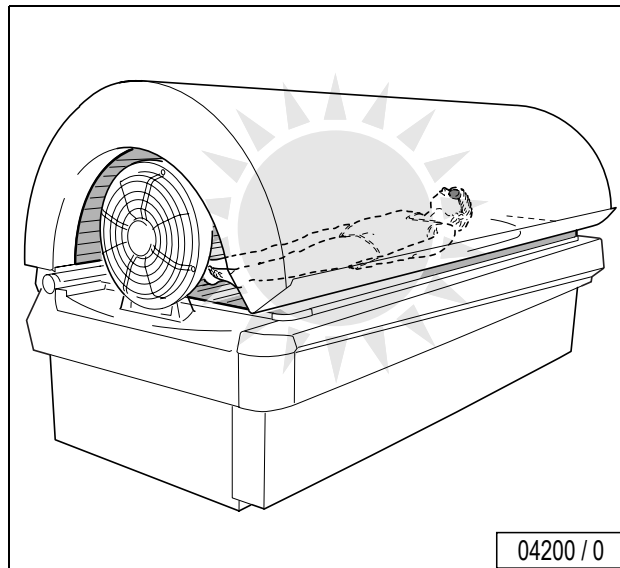

Operation

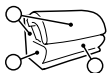

Settings during start-up

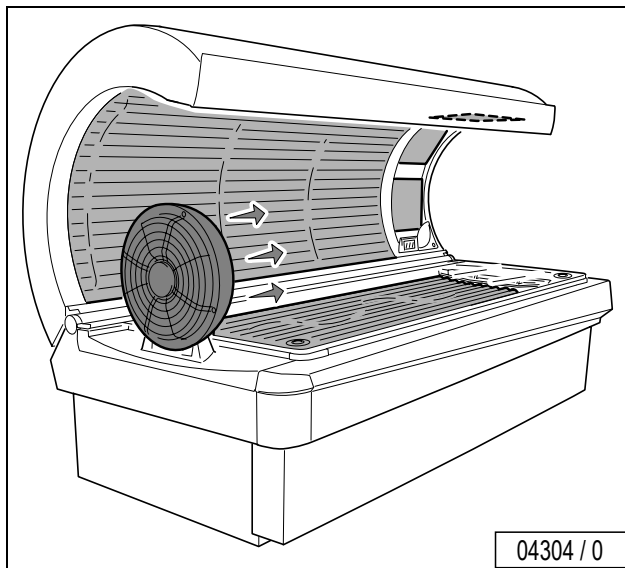

To interrupt tanning session

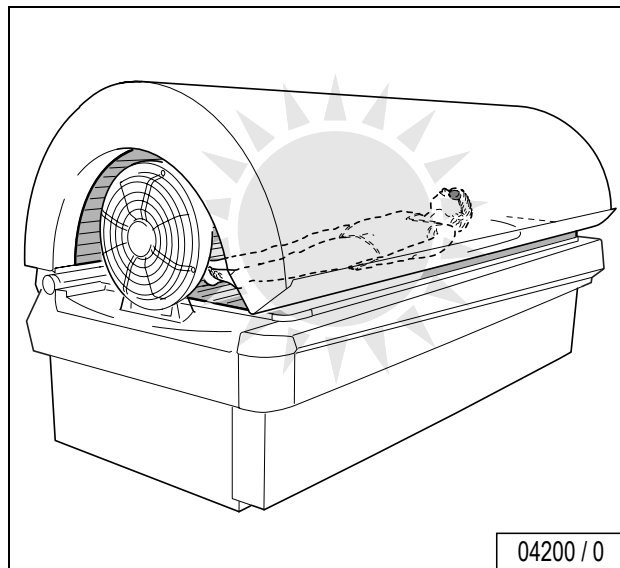

The tanning time can be interrupted during tanning by switching off the UV lamps:

- Press START/STOP for three (3) seconds to pause or stop tanning.
- Press START/STOP again for three (3) seconds to restart the lamps.

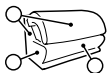

Face tanner

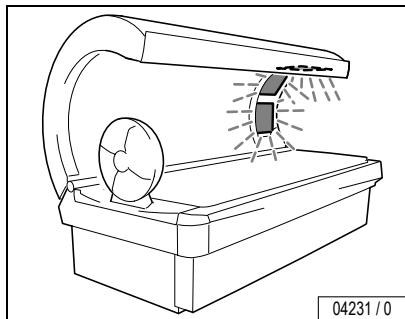

Press for three (3) seconds.

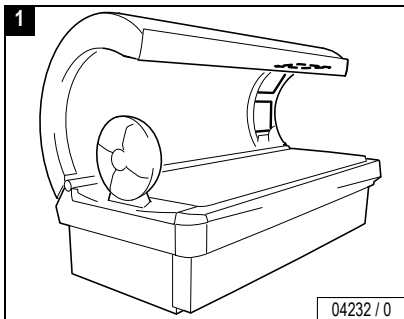

One (1) minute delay.

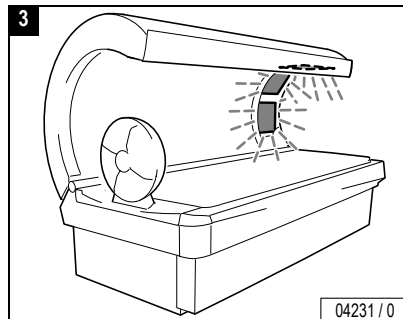
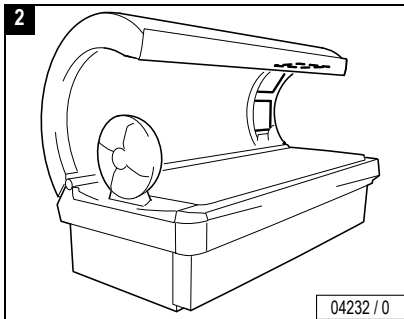

Switching the face tanner OFF:

- Press button  for three (3) seconds.

Switching on face tanner again:

- Press button again. It takes approx. one (1) minute until the face tanners reach their full output.





Operation



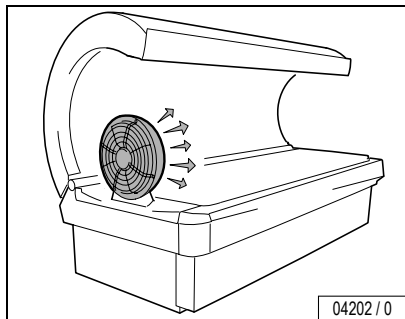

Surround cooling – Adjust speed



– Press button  to change the intensity of the air stream.

Switching the body ventilator OFF:

– Press button for three (3) seconds.

Switching on again:

– Press button again.

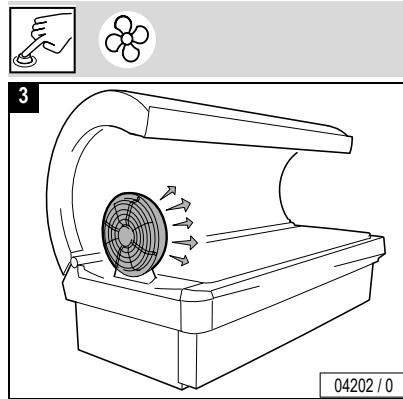
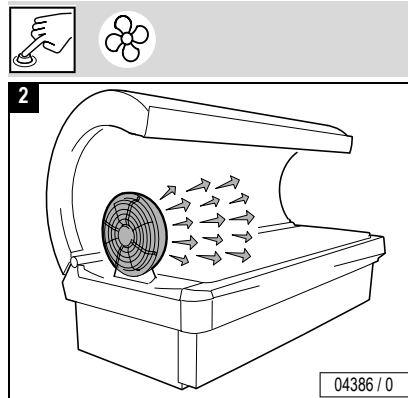
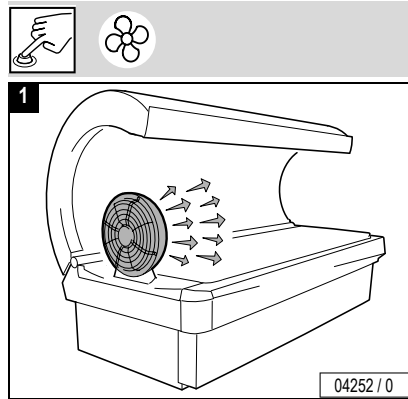



3s

4

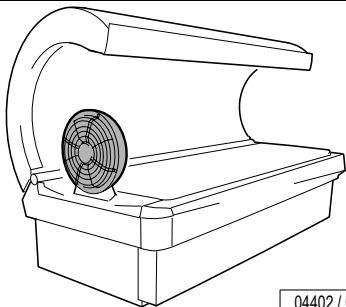

04402 / 0



5

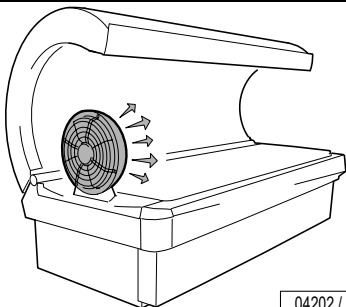

04202 / 0



Operation





Technical data

Model:	Soltron S-40 Champ *** Super
Rated power consumption:	9,800W
Rated voltage:	230 V
Rated frequency:	60 Hz
Rated fusing:	40 amp 3-pole 60 amp 2-pole
Conformity mark:	



Technical data

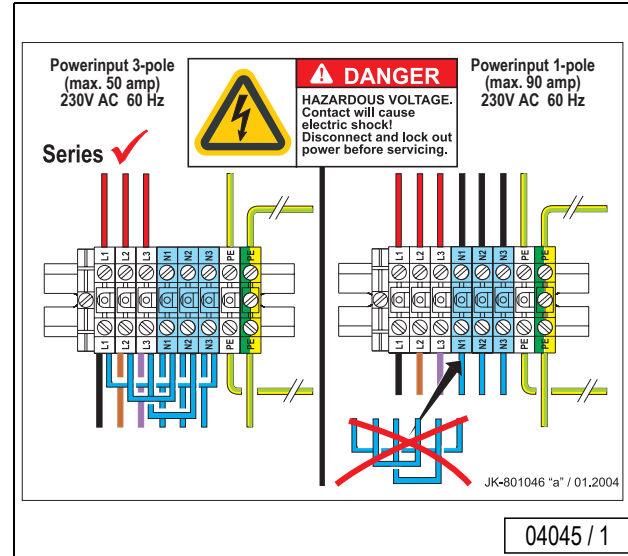



Bed tolerance in room

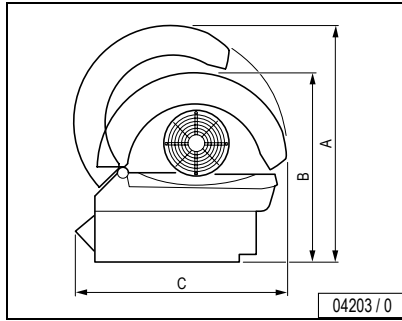

A = 55.70 in
B = 44.29 in
C = 48.43 in
D = 79.33 in
E = 86.61 in
F = 28.35 in

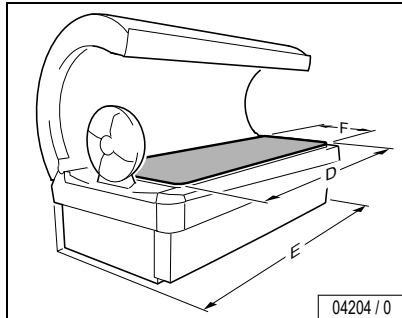

Maximum room temperature / Humidity

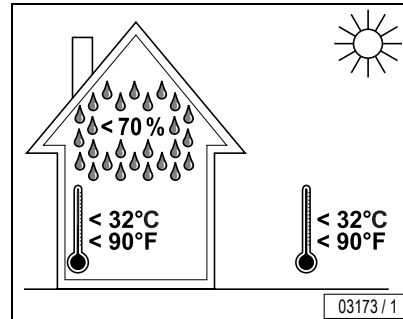

Maximum permissible load

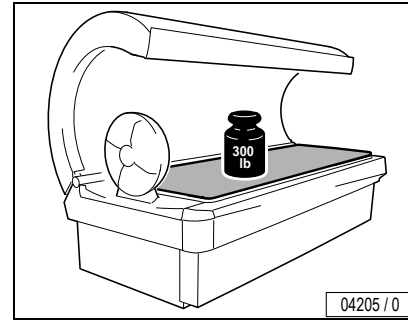

WARNING!

Warning – possible breakage of the acrylic panel!

Severe cuts from glass and burns from hot lamps may result.

- Only one adult person is allowed at the same time.
- People with more than 300 lbs must not use the device at all.















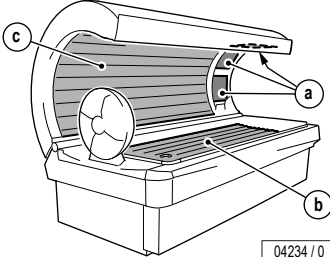

Scheduled maintenance – filters

/50 h	③ 4 x			51937		40
	⑤ 2 x			800767		41



Scheduled maintenance – UV lamps, starters

	S-40 Champ *** Super			
500 h	 04234 / 0	a) 3 x  JK 100723 400 W		100723 37
		b) 14 x  Soltron VHP 15 120 W		12555 33
		c) 24 x  Soltron VHP 15 120 W		12555 35
1000 h		b) c) 38 x  S12		10012



The UV high-pressure lamps used, JK 100723 (face tanner), are broadband radiators that can be operated with different wattages.



UV low-pressure lamps: Clean with plain water (damp cloth).



Scheduled maintenance – Filter panel

1,500 h	⑤		702808	33
3,000 h	①		702609	37



Filter panels: Clean with plain water (damp cloth).



Relamping / maintenance instructions

It is imperative that you, the owner and/or operator, check all components for any signs of wear which may occur through normal use.

- Observe the cleaning and maintenance schedule specified in the maintenance table on Page 37 to 31.
- Only replace UV low-pressure lamps with the original lamp type or with compatible lamps.
- Only replace UV high-pressure lamps with the original lamp type or with compatible lamps.

Should you require any assistance or need additional information, please call Global Service Division at 1-800-643-0086, Monday through Friday 8:00 a.m. - 17:00 p.m. CST



CAUTION – Damage due to improper maintenance!

Improper maintenance can cause the device to be damaged or to become unusable.

- Always comply with the specified maintenance intervals.
- Follow the cleaning instructions.
- If the maintenance intervals for the UV lamps are exceeded or incompatible UV lamps are installed, the share of harmful UVB radiation may increase. Sunburn and other skin damage may result.



Danger of burns from hot lamps and device parts

WARNING! If the tanning device was operated before being switched off and opened, lamps and housing parts may be hot.



– Before replacing lamps or other spare parts, wait until lamps and metal parts of the device have cooled down sufficiently.



Danger of pinching!

When opening and closing the tray, panels and covers, you can pinch your fingers.



UV low-pressure lamps, lower section

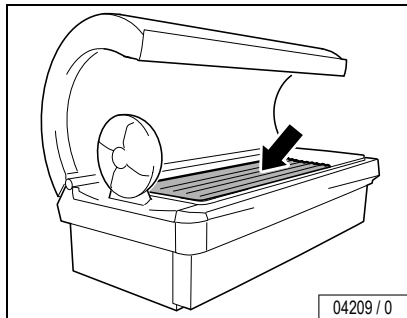
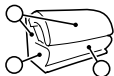

04209 / 0

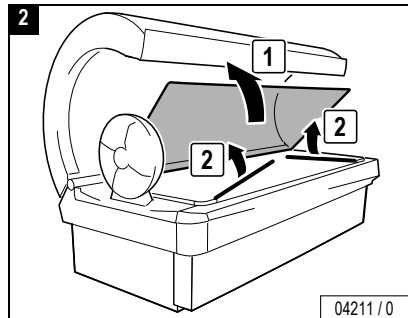

04211 / 0

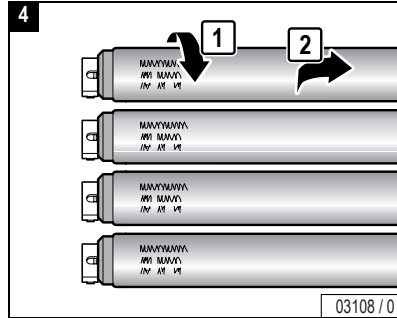

03108 / 0



De-energize device!

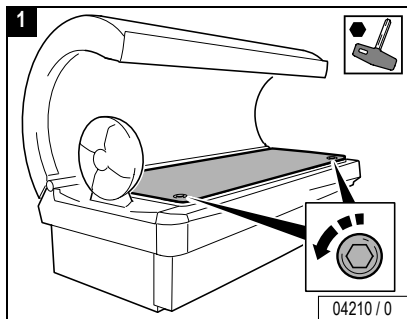

04210 / 0

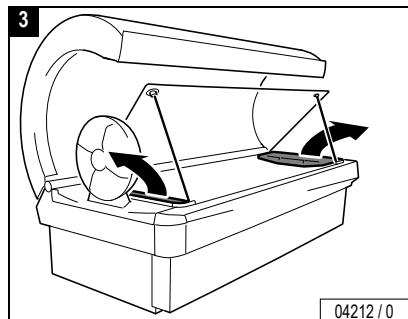

04212 / 0

Maintenance 

...



Maintenance

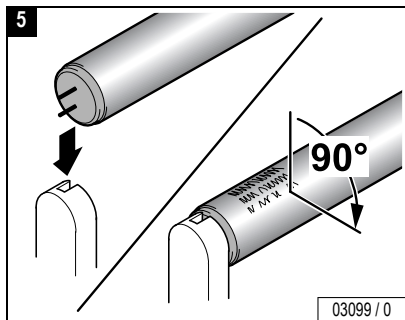

Close:

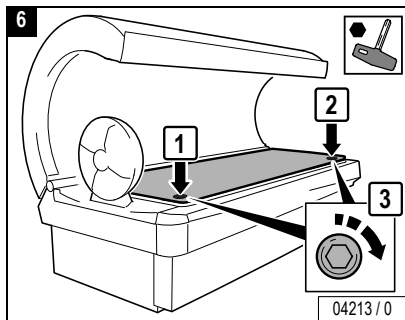



UV low-pressure lamps, canopy

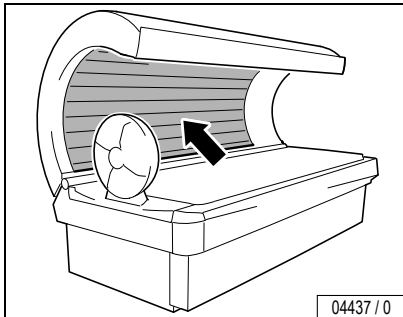
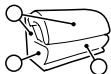

Danger of injury from the canopy panel!

WARNING! The canopy panel is heavy and falls down by itself after unscrewing the 3 screws.

- Support canopy panel.
- Loosen screws in the specified order.



De-energize device!

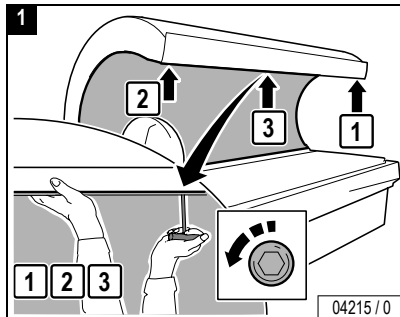

Caution!

Protect acrylic glass panel (1).

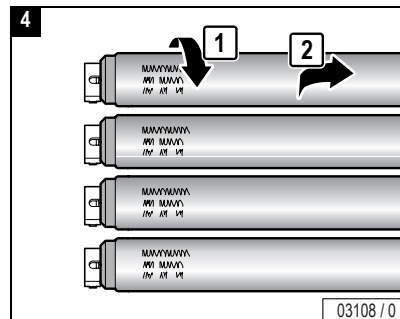
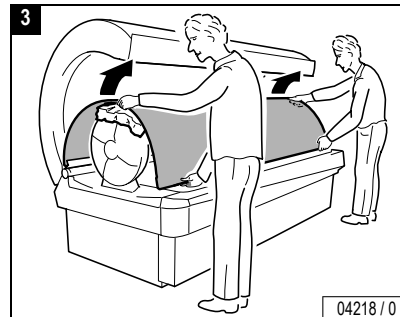
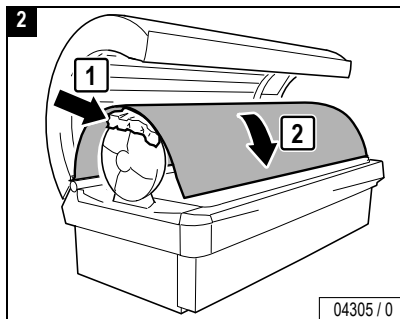

Maintenance



Maintenance

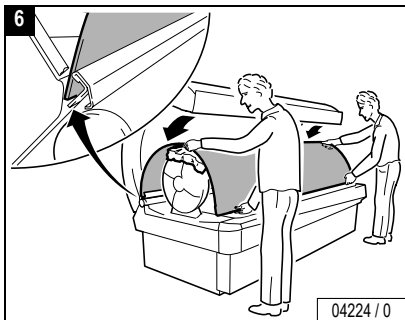
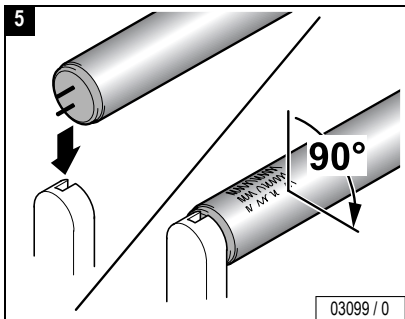

Close:

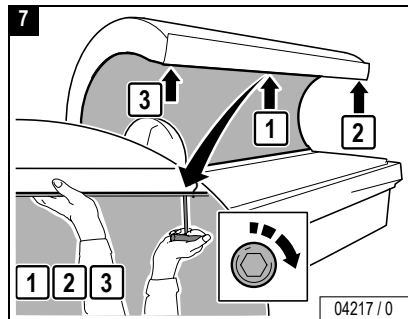



UV high-pressure lamps, canopy

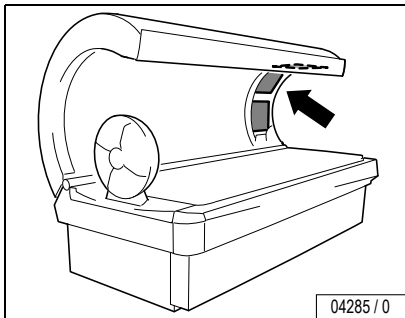
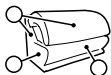

Danger of injury from the canopy panel!

- WARNING!** The canopy panel is heavy and falls down by itself after unscrewing the 3 screws.
- Support canopy panel.
 - Loosen screws in the specified order.



De-energize device!

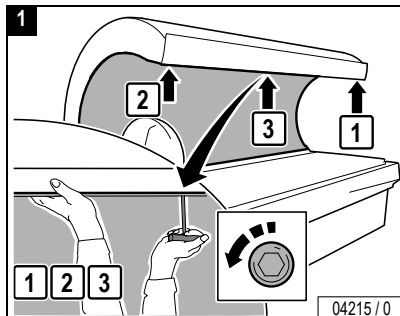

Caution!

Protect acrylic glass panel (1).

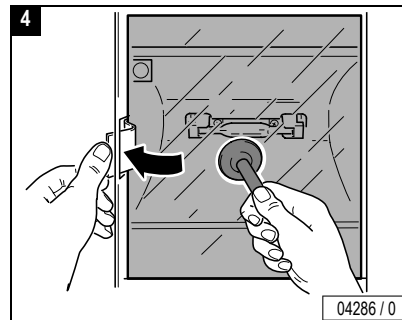
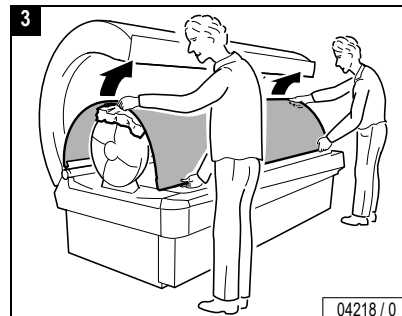
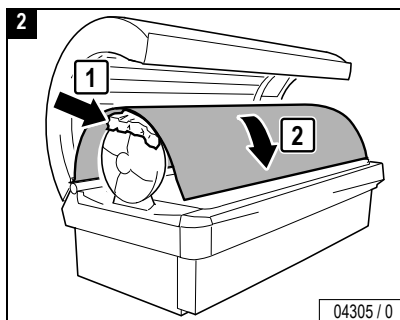

Maintenance

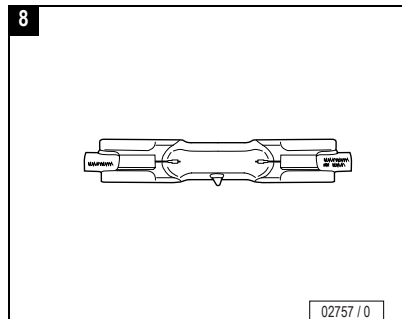
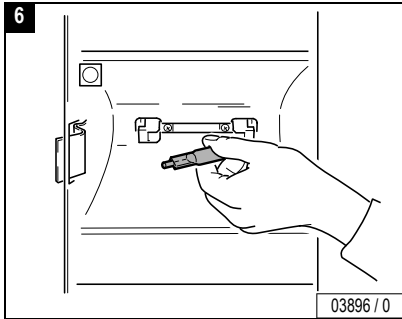
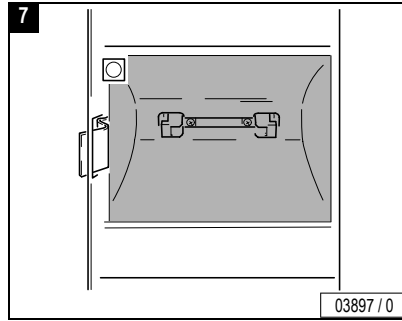
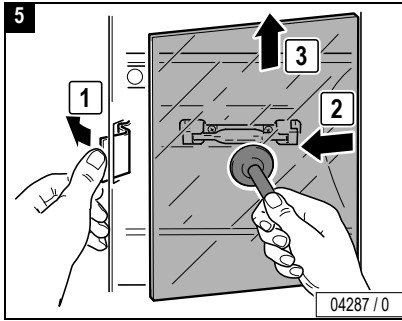

CAUTION!

Do not touch the glass bulbs of the UV high-pressure lamps with your bare fingers! Remove soiling thoroughly.

– Only touch new UV high-pressure lamp with a cloth – see Figure 9.

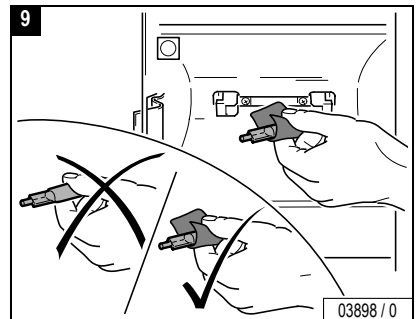



- Check safety switch:

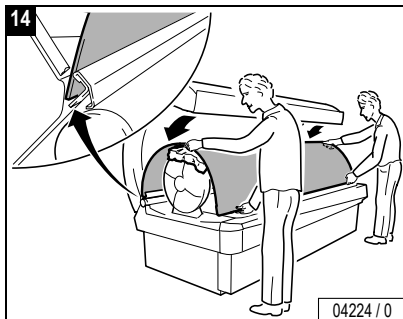
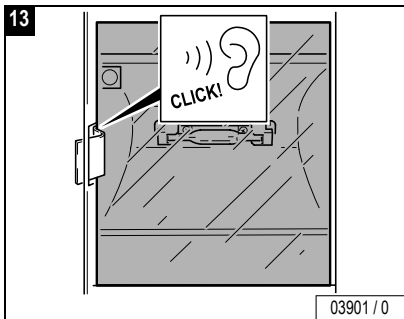
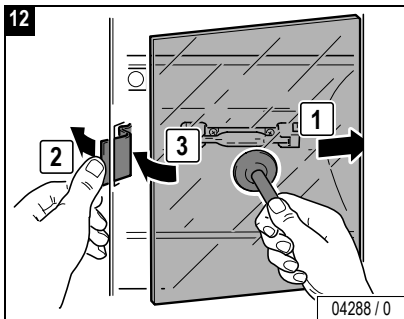
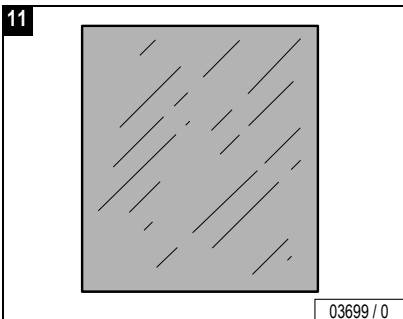
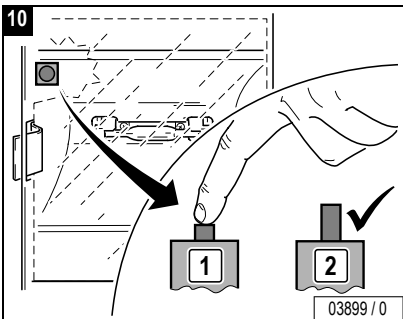

Close:

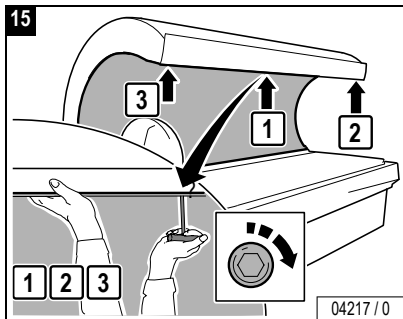

Maintenance





Lower section, filter

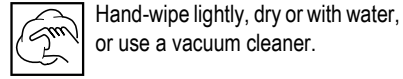
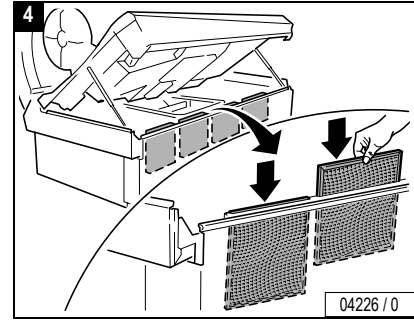
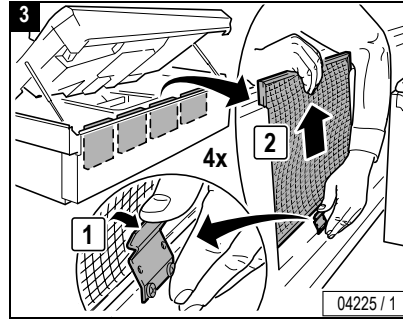
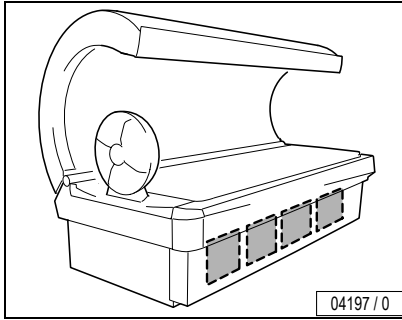
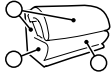

De-energize device!

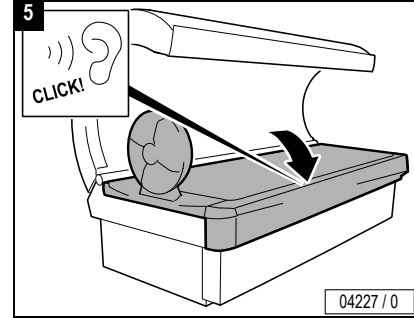
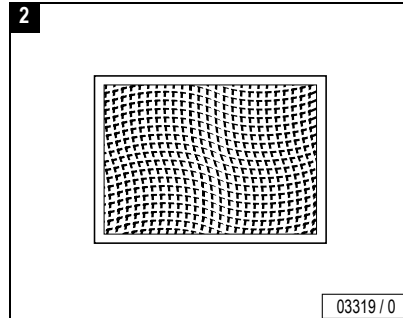
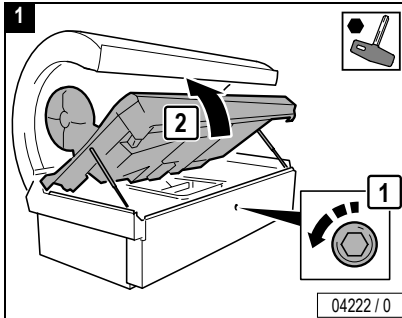

Maintenance



Canopy, filter mats

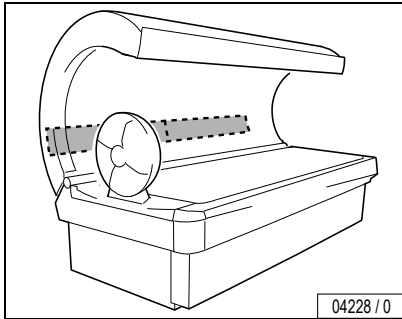
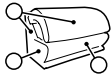

Caution!
Protect canopy with blanket (2).

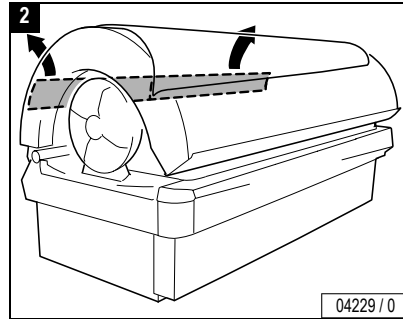
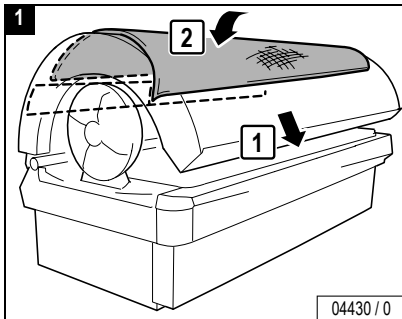

Rinse with water or
replace.

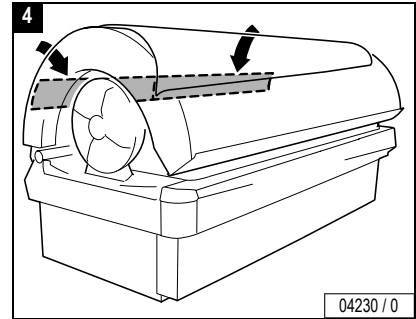
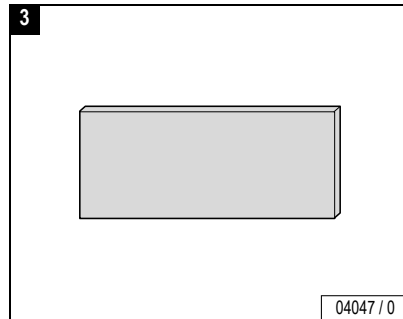

Maintenance 





Troubleshooting

Problem:	Cause/Solution:	Page
The equipment does not work.	Maximum tanning time has been exceeded.	
	A safety switch has responded: <ul style="list-style-type: none"> • Has the bed been closed? • Has the lower acrylic glass panel (bed) been closed? • Has the upper panel been closed? • Have the filter panels been closed? 	40 33 35 37
	Electronic problem: <ul style="list-style-type: none"> • Press the Start/Stop button (reset). 	
	The equipment is overheating: <ul style="list-style-type: none"> • Lower section: Check the filter and clean or replace as necessary. • Canopy: Check the filter and clean or replace as necessary. • Leave the equipment to cool down and then restart. 	40 41
Some of the lights are not working.	Lamp or starter is defective. <ul style="list-style-type: none"> • Replace the lamp or starter. 	33, 35

If the equipment still does not work or if another problem arises, please contact the customer service division at:



Global Service Division
#1 Walter Kratz Drive
Jonesboro, Arkansas 72401

 (800) 445 0624



Index

A

Accessories 18
Acrylic glass panels 12

B

Bed tolerance in room..... 25

C

Children 8
Circuit breakers..... 27
Cleaning schedules 28
Contact 17

D

De-energizing device 27
Disposal of lamps 14

E

Equipment..... 11
Export 11
Exposure schedule III
Eye injuries 7

F

Face tanner, operation 21
Fan delay 19
Filter mats, Canopy, cleaning/replacing 41
Filter panels, cleaning 39
Filter, lower section, cleaning..... 40
Frequency 24
Fusing 24

G

Global Service Division II

I

Intended use 7

L

Label II
Load, maximum..... 25
Long-term consequences..... 8

M

Maintenance schedules 29
Minors 8

O

Operator, important information7
Order numbers 29, 30
Overview
 Maintenance 28
 Operation..... 18

P

Plastic..... 13
Power consumption 24
Powerinput 24
Preparation time 19

R

Relamping instructions, general 32
Room temperature, maximum 25

S

Safety information III, 7
Settings at start 20
Skin types 15
Spare parts..... 12
Start of tanning session 19
Sun screen 15
Surround cooling, operation 22



Index

Symbols	9	V	
Cleaning	10	Ventilation	15
Filter panel	9	Voltage	24
Filter/filter mat	10		
High-pressure lamp	9		
Hot surface	9		
Press button	9		
Replacing	10		
Safety switch	10		
Soltron key	9		
Visual inspection	10		
T			
Tanning instructions	14		
Tanning times	III		
Technical data	24		
Termination of tanning	20		
Troubleshooting	42		
Type label	II		
U			
UL Standard	11		
UV high-pressure lamps			
Canopy	37		
UV lamps, maintenance schedule	30		
UV low-pressure lamps			
Canopy	35		
lower section	33		

Warranty

Soltron – Limited Warranty

Soltron warrants its products to be free from defects in materials and workmanship under intended normal use as described in the unit's Operation and Instruction Manual, for a period of three (3) years from date of sale.

This Limited Warranty applies only to the original purchaser of the equipment through Soltron or its authorized dealer or distributor, and is not transferable.

Soltron obligations under this warranty are limited to repair or replacement of any defective part without charge for that part to the original purchaser, with the following exceptions:

- A. Fluorescent lamps are warranted against defects for a period of thirty (30) days from date of sale.
- B. Only parts obtained through Soltron, its authorized dealers or distributors may be used. Transportation costs for parts shipped to the consumer and the return of defective parts to Soltron are not included.
- C. Labor will be furnished without charge for ninety (90) days from date of purchase only. All labor and related charges must be authorized by Soltron prior to start of repairs, and must coincide with Soltron established rates and time allotment policy.
- D. Acrylic: Refer to Manufacturer's Acrylic Warranty Policy.

It is imperative that the original customer completes and returns the enclosed warranty card within 10 days after purchase to insure valid registration and coverage for potential claims.

If the warranty card is not registered, proof of purchase from Soltron or its authorized dealer or distributor will be required prior to any consideration on warranty claims. This could result in service delays.

This warranty is extended to the individual or legal entity, whose name appears on the warranty registration card filed with Soltron, or whose name appears on the original sale document and may not be transferred to any other individual or legal entity.

This warranty does not apply to any failure of the product, or any parts of the product due to alterations, modifications, misuse, abuse, accident, improper maintenance, improper installation, acts of God or if the serial number on the product has been removed, altered or defaced. Adequate packaging must be used for returned goods to prevent freight damage.

There are no warranties which extend beyond the description on the face hereof. There is no express or implied warranty of fitness of merchantability.

The remedies provided in this limited warranty are the exclusive remedies provided to the purchaser by Soltron and are provided in substitution of all other remedies. Consequential and incidental damages are excluded.

No person, firm or corporation is authorized to obligate Soltron for any liability in connection with the sale or use of these goods.

Warranty

Limited Acrylic Warranty

Soltron warrants its acrylic sheets to be free from defects in material and workmanship, under intended normal use, for a period of one (1) year from date of sale of the tanning bed. Due to the tanning lotions, cosmetics, disinfectant and improper cleaners used on tanning surfaces that cannot be controlled by Soltron, after the first thirty (30) days of warranty period. Acrylic will be subject to a prorated cost to the consumer on breakage.

Soltron obligations do not include transportation charges on replacement acrylic.

Soltron assumes no liability for the cost of removing defective sheets or installing replacement sheets, nor for damage to persons or property.

To make a claim, contact an authorized dealer or distributor of Soltron or Global Service Division with the model number, the serial number, and the date of purchase of the bed in which the acrylic will be used.

There are no warranties which extend beyond the description on the face hereof. There is no express or implied warranty of fitness or merchantability.

The remedies provided in this limited warranty are the exclusive remedies provided to the purchaser by Soltron and are provided in substitution of all other remedies. Consequential and incidental damages are excluded.

Global Service Division

#1 Walter Kratz Drive
Jonesboro, Arkansas 72401

☎ (800) 445 0624

Warranty Claims

Policy & Procedures

1. When to file a Warranty Claim:

In the event that your tanning system is not functioning properly under intended normal use as described in the unit's Operation an Instruction Manual, you may then have established cause to file a Warranty Claim.



NOTE: Both the tanning system and legal registered owner must meet the criteria established under Soltron Limited Warranty as described in this manual before any Warranty Claim will be considered.

2. Where to call to place a Warranty Claim:

Soltron is supported nationwide by an extensive dealer/distributor network through whom the majority of our units are sold. These dealers/distributors are required by contract to stock sufficient parts to meet the various warranty and nonwarranty needs of their customers.

Therefore, in order for you to properly file a Warranty Claim, you must locate the name and phone number of the dealer/distributor through whom you purchased your unit. Normally this information can be easily located either on your paid invoice or other proof of purchase documentation that you received when taking delivery of the unit.

Next, notify the dealer/distributor of the serial number, model number and date unit was purchased. This will initiate the Warranty Claim process.

Upon determination of the problem, your dealer/distributor can then supply you with the part(s) and proper instructions to return your unit to

working order.

Each dealer/distributor has their own internal procedure for handling Warranty Claims and credits.

NOTE: Soltron, the manufacturer, does not involve itself in the direct handling of a Warranty Claim except where mitigating circumstances apply and where required by law.

Parts Warranty Claim/Credit Review

1. Customer calls Soltron and notifies the Service Department of problem
2. Soltron Service Department determines course of action.
3. Soltron ships part and R.A.I. to customer freight collect and bills customer on net30 basis for part only.
4. Customer, within 15 days of receiving new part, returns defective part to Soltron along with R.A.I.
5. Upon receipt of defective part and R.A.I., Soltron issues customer a credit invoice which offsets original bill. Customer's account is returned to zero balance concerning this claim.



NOTE: If part returned to Soltron proves to be operational and not defective, or if product code numbers on part do not correspond with individual unit date on file with Soltron, then a 30% restocking fee will be charged in addition to the retail purchase price of part.

Warranty

Acknowledgment of the Agreement is not required for acceptance of the foregoing stipulations.

Labor Warranty Claim/Credit Procedures

Soltron furnishes labor without charge for a period of 90 days from date of purchase. All labor and related charges must be authorized by Soltron prior to start or repairs, and must coincide with Soltron established rates and time allotment policy.

Please contact our Service Department for authorization and billing procedures.

Limited Lifetime Warranty

Soltron warrants specific individual components of the Competition Tanning Systems against defects in materials and workmanship for the life of the product. Coverage is limited to units purchased after November 1, 1994.

This warranty is restricted by the following components only:

- Steel Back Panels
- Structural Steel Frame Components
- Exterior Steel Body



NOTE: Components are warranted on an individual basis and not as they may effect the complete product.

Warranty coverage does not include cosmetic abnormalities such as scratches, nicks, dents, oxidation of paint or other cosmetic changes that

do not interfere with the designed function of the unit.

This warranty does not include failure of the product due to alteration, modifications, misuse, abuse, improper maintenance, improper installation or repair.

This warranty is not transferable and is only applicable to the original purchaser named on a completed and registered warranty record at Soltron headquarters.

Soltron obligations do not include transportation charged on the shipping of new components to the customer or on the return of defective components of the manufacturer. All freight charges must be paid by the customer.

There are no warranties which extend beyond the description on the face hereof. There is no express or implied warranty of fitness or merchantability.

The remedies provided in this limited warranty are the exclusive remedies provided to the purchaser by Soltron and are provided in substitution of all other remedies. Consequential and incidental damages are excluded.



Notice: Any misuse, abuse, modification, alteration, improper maintenance, improper installation, etc. of this product or its intended use will subject said party to direct responsibility and liabilities for any and all consequences resulting from such action. Furthermore, such actions will void all warranties and may relieve Soltron of any liabilities relating to said product.

